

IEC Appliance Inlet C14 with Fuseholder 1- or 2-pole

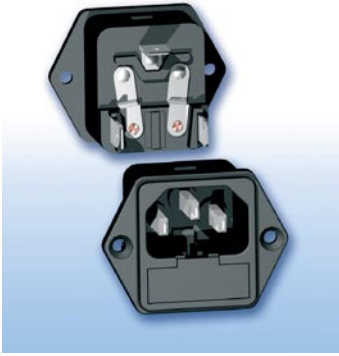

C14

 70° C

**Description**

- Panel Mount:
- Screw-on from front side,
- Appliance Inlet,
- Protection class I Fuseholder for fuse-links 5 x 20 mm 2-pole, Protection class I, Pin temperature 70 °C
- Solder terminals or quick connect terminals

Approvals

- CSA File Number: 1084381

Characteristics

- The fuseholder is accessible from the equipment front
- The fuse drawer "Fingerrip" can be removed by hand
- With or without rear-side insulation cover

References

We recommend for new applications the type [1062](#)
 Last order possibility: 31.05.2011

Weblinks

[pdf](#), [html](#), [General Product Information](#), [Approvals](#), [RoHS](#), [CHINA-RoHS](#), [Mating Connectors](#), [e-Store](#), [SCHURTER-Stock-Check](#), [Distributor-Stock-Check](#), [Accessories](#)

Technical Data

Ratings IEC	10A / 250VAC; 50Hz	Appliance Inlet	C14 acc. to IEC/EN 60320-1
Ratings UL/CSA	10A / 250VAC; 60Hz		UL 498, CSA C22.2 no. 42 (for cold conditions) pin-temperature 70 °C, 10A, Protection Class 1
Dielectric Strength	> 3kVAC between L-N > 1.5kVAC between L/N-PE (1 min/50Hz)	Fuseholder	2-pole, acc. to IEC 60127-6, for fuse-links 5 x 20 mm
Allowable Operation Temp.	-25 °C to 70 °C	Power Acceptance @ Ta > 23°C	Admissible power acceptance at higher ambient temperature see derating curves
Degree of Protection	from front side IP 20 acc. to IEC 60529		
Protection Class	Suitable for appliances with protection class 1 acc. to IEC 61140		
Terminal	Solder terminals or quick connect terminals Solder terminals or quick connect terminals straight		
Material: Housing	PA6, black / grey / white, UL 94V-0		

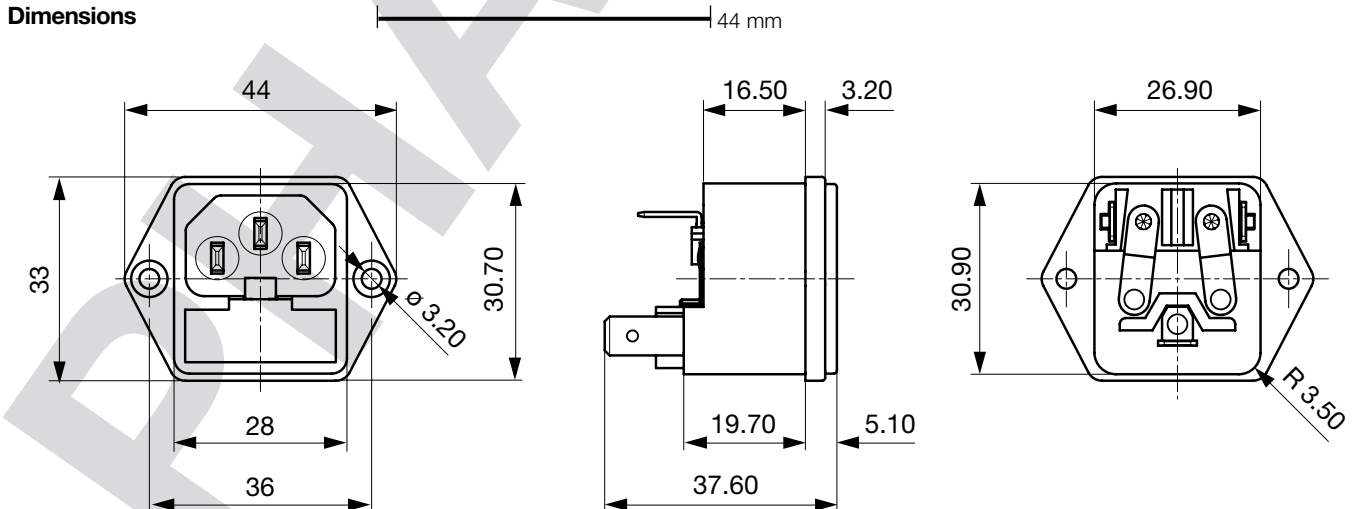
Dimensions

Length of the terminal please find at the order code configuration table

Config. Code

1092 - H - A B C N - D - E G O

The characters are placeholders for the correspondingly keys of selections from the key tables.

1092 - **H** - A B C N - D - E G O = Type

Type	Configuration key
protection class 1	X

1092 - H - **A** B C N - D - E G O = Terminals

Terminal L	Configuration key
short solder terminal (L = 4.8 mm)	2
long solder terminal (L = 8.5 mm)	3
Blade terminal (2.8 x 0.8 mm)	7
Blade terminal (4.8 x 0.8 mm)	8
Blade terminal (6.3 x 0.8 mm)	9
connection to fuse holder	B



1092 - H - A **B** C N - D - E G O = Terminals

Terminal N	Configuration key
short solder terminal (L = 4.8 mm)	2
long solder terminal (L = 8.5 mm)	3
Blade terminal (2.8 x 0.8 mm)	7
Blade terminal (4.8 x 0.8 mm)	8
Blade terminal (6.3 x 0.8 mm)	9
connection to fuse holder	B

Symbols similar as in table A

1092 - H - A B **C** N - D - E G O = Terminals

Terminal Ground	Configuration key
short solder terminal (L = 4.8 mm)	2
long solder terminal (L = 8.5 mm)	3
Blade terminal (2.8 x 0.8 mm)	7
Blade terminal (4.8 x 0.8 mm)	8
Blade terminal (6.3 x 0.8 mm)	9

Symbols similar as in table A

1092 - H - A B C **N** - D - E G O = Terminal Fuseholder

Terminal Fuseholder	Configuration key
solder terminal	1
Blade terminal (2.8 x 0.8 mm)	7
Blade terminal (4.8 x 0.8 mm)	8
Blade terminal (6.3 x 0.8 mm)	9

1092 - H - A B C N - **D** - E G O = Color

Color	Configuration key
jet black; RAL9005	A
silver grey; RAL7001	B
pure white; RAL9010	D

1092 - H - A B C N - D - **E** G O = Style

Style	Configuration key
flange with countersunk holes	1
flange with through holes	2

1092 - H - A B C N - D - E **G** O = Dimension X

Dimension "X"	Configuration key
00	

The dimension "X" is displayed in (1/10 mm). This information is also valid for the order code

1092 - H - A B C N - D - E G **O** = Features

Features	Configuration key
dead cover	1
holder for 1 or 2 fuses (text legible, when inlet on top)	4
holder for 1 or 2 fuses (text legible, when inlet on bottom)	5

Variants

Config. Code	Description	Order Number
1092-X-BB88-A-1004	1092, IEC Power Entry Module C14, 70°C, version: 1, L: connection to fuse holder, N: connection to fuse holder, ground: Blade terminal (4.8 x 0.8 mm), fuseholder: Blade terminal (4.8 x 0.8 mm), color: jet black; RAL9005, design: flange with countersunk holes, dimension X: 00, features: holder for 1 or 2 fuses (text legible, when inlet on top),	4304.6112

The listed variants should be available from stock. Other versions on request www.schurter.com/contact

Packaging unit 50 Pcs

Accessories

Description

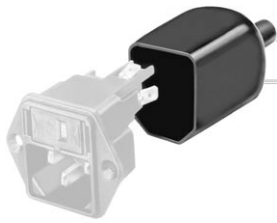

0859.0047
Rear Cover

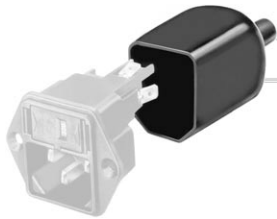

4311.9403
Rear Cover

Mating Outlets/Connectors

Category / Description

Appliance Outlet Overview complete



IEC Appliance Outlet F, Screw-on Mounting, Front Side, Solder Terminal	4787
IEC Appliance Outlet F, Snap-in Mounting, Front Side, Solder or Quick-connect Terminal	4788
IEC Appliance Outlet F or H, Screw-on Mounting, Front Side, Solder, PCB or Quick-connect Terminal	5091
IEC Appliance Outlet F or H, Screw-on Mounting, Front Side, Solder or Quick-connect Terminal	5092

Appliance Outlet further types to 1092

Connector Overview complete



IEC Connector C15, Rewireable, Straight	0101
IEC Connector C15A, Rewireable, Straight	0102
IEC Connector C15A, Rewireable, Straight	0102-G
IEC Connector C15A, Rewireable, Angled	0112
IEC Connector C13, Rewireable, Angled	4012

Connector further types to 1092

Power Cord Overview complete



Power Cord with IEC Connector C13, Angled	0311
Power Cord with IEC Connector C13, Angled	3011
Power Cord with IEC Connector C13, Angled	3012
Power Cord with IEC Connector C13, Angled	3013
Power Cord with IEC Connector C13	3020

Power Cord further types to 1092